

46-560 R and R center link and tie rod end boots

Preliminary work:
Center link removed (46-550).
Tie rod removed (46-540).

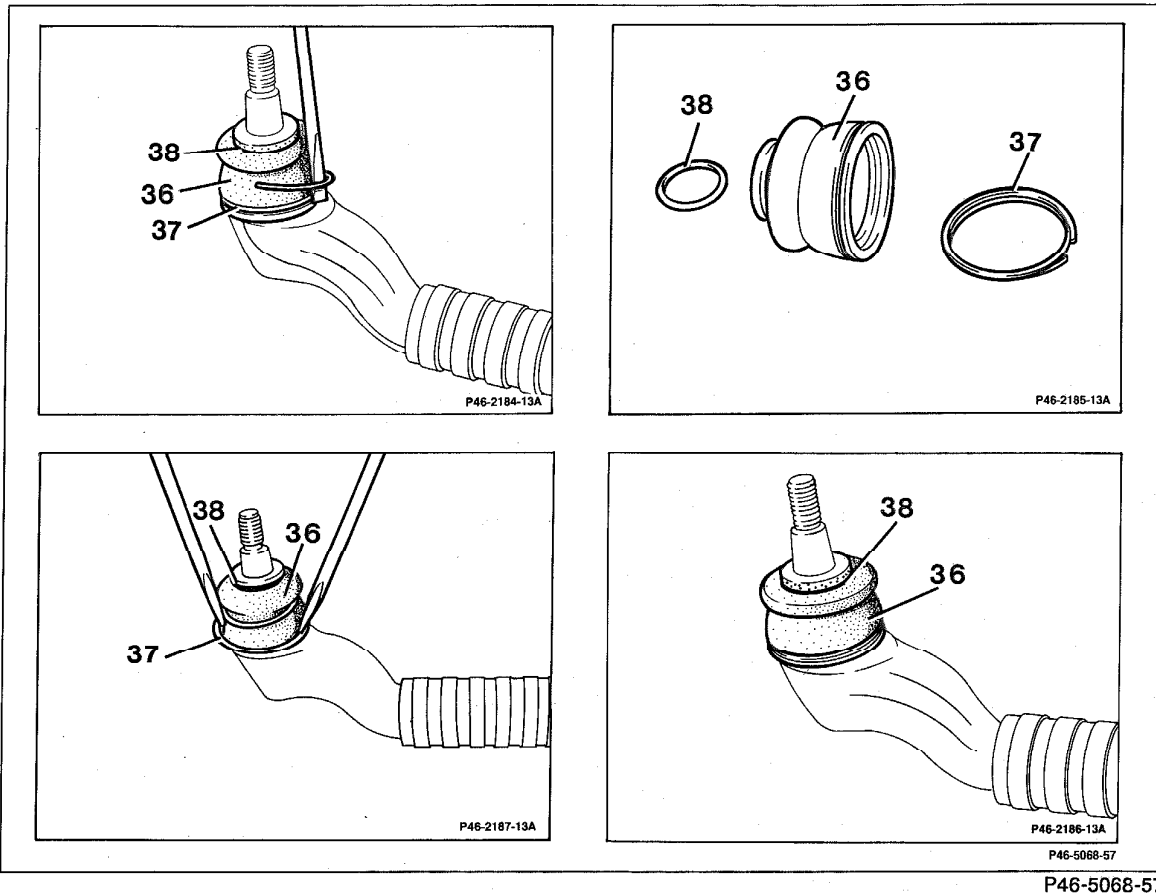

- | | |
|----------------------------------|--|
| Flat wire ring clip (37) | remove with small screwdriver. Pull off rubber boot (36) together with plastic mounting ring (38). |
| Rubber boot (36) and joint | fill with multi-purpose grease, approx. 3 cm ³ . |
| Plastic mounting ring (38) | install in rubber boot (36). |
| Rubber boot (36) | slide onto ball bolt or joint head. |

⚠ CAUTION!

The edges on the screwdriver should be rounded to avoid cutting the rubber boot when installing the flat wire ring clip.

Flat wire ring clip (37)

carefully install in rubber boot (36) with screwdrivers.

Note

When installing the flat wire ring clip (37), check rubber boot (36) again for damage.

Approved grease for ball joint

Multi-purpose grease

Refer to factory approved service products list ¹⁾

¹⁾ Supplied with owner's literature or available through your local authorized Mercedes-Benz Dealer.

Note

The maintenance-free joints are provided with a lifetime grease packing. The seal to prevent penetration of dirt is decisively important for the service life of these joints. Rubber boots (36) damaged during installation must be replaced immediately to prevent penetration of dirt leading to joint wear. For this reason it is also necessary to carefully check the joints from time to time.

When a damaged rubber boot (36) is detected on a used joint, the affected joint must be replaced completely.

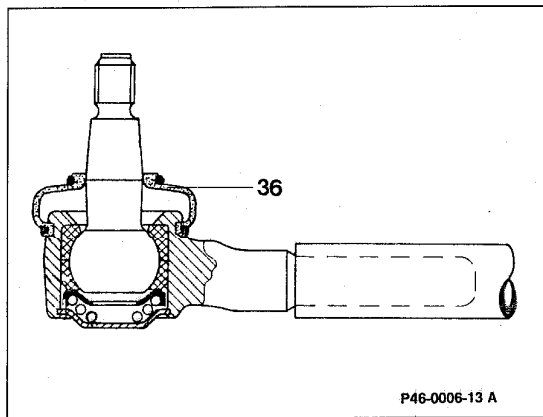

P46-0006-13 A

P46 0006-13A